

UDCLB / UDCLRS Cemented Carbide Bulb Shape Mold Part

Tool : 2-flute long neck ball UDCLB 2020-0600 (R1 x L6)
 2-flute long neck radius UDCLRS 2020-005-020 ($\phi 2$ x CR0.05 x L2)
 Work material: Cemented carbide VM-40 (90HRA)
 Coolant : Air blow (Nozzle)

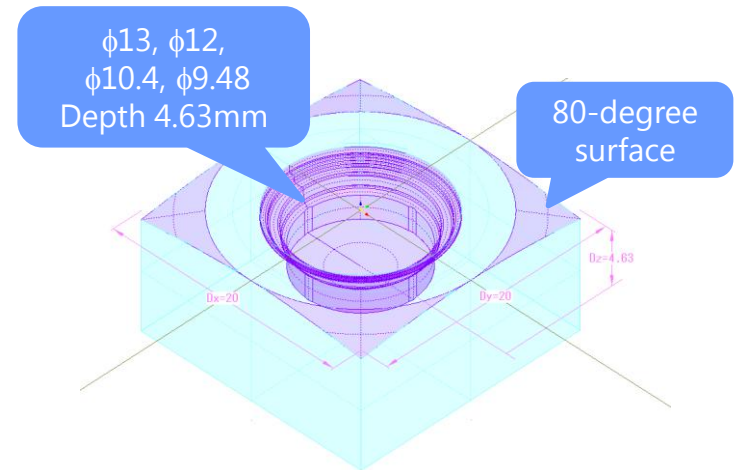
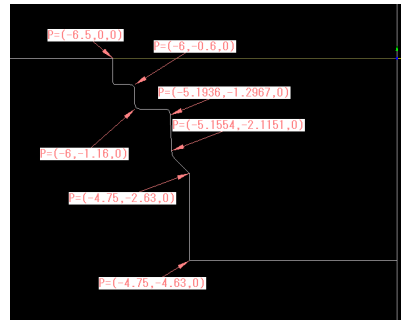
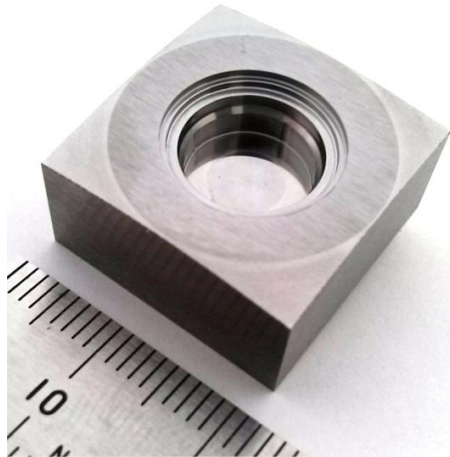

Work size: 20 x 20 x Thickness 10 mm

No.	Process	Series / Size	Spindle Speed (min ⁻¹)	Feed Rate (mm/min)	a _p (mm)	a _e (mm)	MRV (mm ³)	Cycle time
1	Roughing	UDCLB R1 x L6	30,000	300	0.1	0.3	399.4	1:41:21
2		UDCLRS $\phi 2$ x CR0.05 x L2	20,000	750	0.0075	1	22.2	0:23:22
3	Finishing	UDCLB R1 x L6	30,000	300	0.045	0.05	2.5	0:39:21
4		UDCLRS $\phi 2$ x CR0.05 x L2	20,000	750	0.0075	0.1		0:29:27

Total Used 4 pcs

3 hr 14 min