

# CXERS Star Shape & Slotting

**UTCOAT**  
for low hardness material

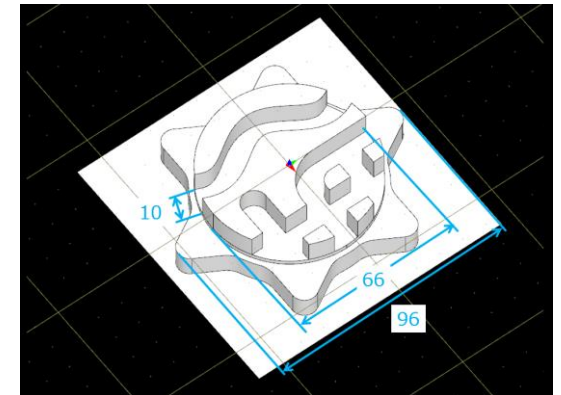
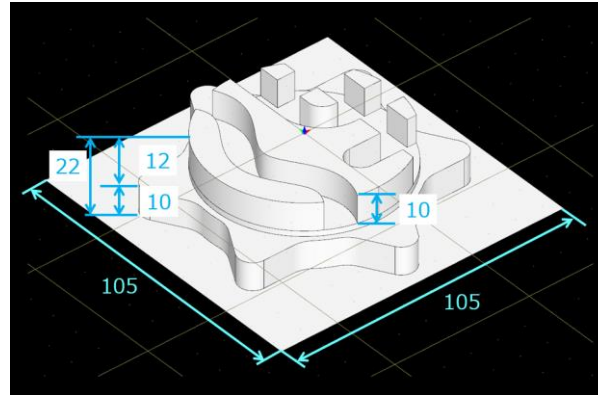

Tool : 4-flute Highly Efficient Radius End Mill with Variable Pitch and Helix  
**CXERS 4100-05-250** (φ10 x CR0.5 x L25)

Work material: S50C

Work size : 105 x 105 x 50 mm

Coolant : Water-soluble

No.	Process	Tool	Spindle Speed (min <sup>-1</sup> )	Feed Rate (mm/min)	a <sub>p</sub> (mm)	a <sub>e</sub> (mm)	Finishing Allowance (mm)	Cycle time
1	Roughing	CXERS 4100-05-250 (φ10 x CR0.5 x L25)	1,920	1,000	22	2	0.2	08:03
2	Roughing		1,920	1,000	22	2	0.1	20:22
3	Semi-finishing		1,920	1,000	12	2	0.02	14:01
4	Finishing		3,200	400	12	8	0	10:43
5	Slotting		1,920	380	10	-	-	02:05

Total 55:14