

CESUS Star Shape & Slotting

UTSCOAT
for stainless steels

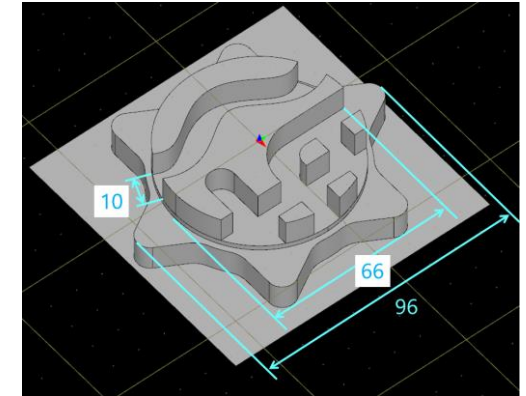
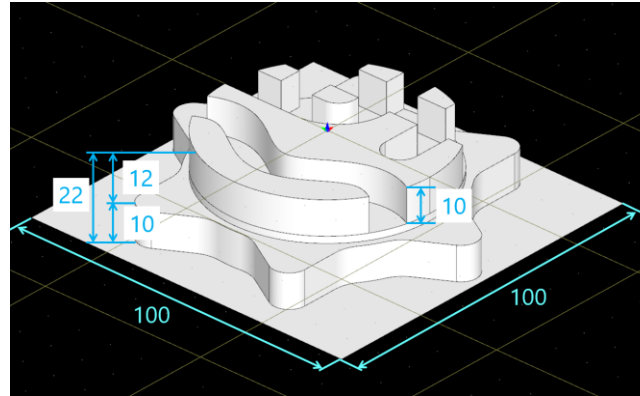
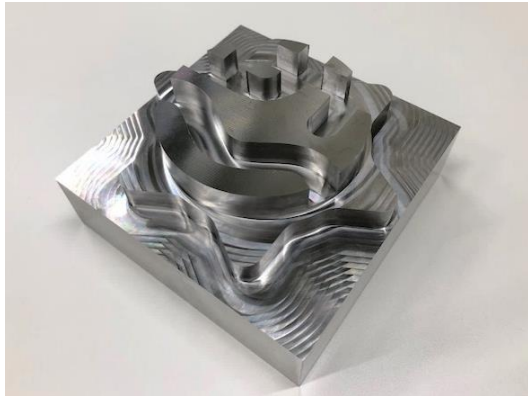

Tool : 4-flute Highly Efficient Square End Mill for Stainless Steels **CESUS 4100-2200** ($\phi 10 \times L22$)
Work material : SUS304
Work size : 100 x 100 x 50 mm
Coolant : Water-soluble

No.	Process	Tool	Spindle Speed (min ⁻¹)	Feed Rate (mm/min)	a _p (mm)	a _e (mm)	Finishing Allowance (mm)	Cycle time
1	Roughing	CESUS 4100-2200 ($\phi 10 \times L22$)	3,200	800	22	2	0.2	08:04
2	Roughing		3,200	800	22	2	0.1	21:04
3	Semi-finishing		3,200	800	12	2	0.02	15:52
4	Finishing		3,200	400	12	2	0	23:54
5	Slotting		2,900	400	10	-	-	02:34

Total 1:11:28